



PRESSIO[®] 2 ICP MONITOR PSO-4000

This page is intentionally left blank.

Table of Contents

1. Figure	5
2. Introduction	5
3. Intended Use	5
4. Warnings and Precautions	6
4.1. Warnings	6
4.2. Precautions	6
4.3. Precautions for Monitoring the Patient During Transport	6
5. Description	6
5.1. Monitor	7
5.2. Power Cable	8
5.3. Catheter Extension Cable	8
5.4. Screens	8
6. Initial Installation	11
6.1. Installing the Battery	11
6.2. Configuring the Time Zone	11
7. Setting-up the System	12
7.1. Equipment Visual Check	12
7.2. Positioning the System	12
8. Cleaning and disinfection procedures	12
8.1. Introduction	12
8.2. Prerequisites	13
8.3. Cleaning procedure	13
8.4. Disinfection procedure	13
8.5. Inspection	13
9. Operating Information	13
9.1. Connecting Cables	14
9.2. Powering on the Monitor	14
9.3. Zeroing the Catheter	14
9.4. Implanting the Catheter	15
9.5. Activating or Deactivating the Physiological Alarms	15
9.6. Adjusting Alarm Thresholds	15
9.7. Connecting and Calibrating the Patient Bedside Monitor	16
9.8. Changing the Monitor	16
10. Advanced Functions	17
10.1. History	17
10.2. Data Transfer	18
10.3. Data Acquisition	18
11. Environmental Conditions, Storage and Shipping	18
11.1. Environmental conditions	18
11.2. Storage	18
11.3. Shipping	19
12. Equipment inspection	19
12.1. Visual inspection	19
12.2. Power-up tests	19
13. Maintenance	19
13.1. Preventive Maintenance	19
13.2. Maintenance	20
14. Recycling	20
15. Warranty	20
16. Symbols	20
16.1. Monitor	20
16.2. Catheter Extension Cable	21
16.3. Catheters	21

17. Troubleshooting	21
17.1. Help Function	21
17.2. Error Codes	21
18. Technical Specifications	22
18.1. General Points	22
18.2. Specifications Concerning Alarms	25
19. Electromagnetic Compatibility	27
19.1. Consequences of electrostatic or electromagnetic discharges	27
19.2. Guidance and manufacturer's declaration tables	28
20. References	29

CAUTION

Federal (USA) law restricts this device to sale by or on the order of a physician.

NOTE

Read the Instructions for Use carefully before using the Pressio® 2 ICP Monitor (hereinafter referred to as Monitor). Do not use the Quick Start Guide before reading the current Instructions for Use.

Refer to the Instructions for Use of the specific Pressio® Catheter being used (hereinafter referred to as Catheter): PSO-PB, PSO-PT, PSO-VT, PSO-PBT, PSO-PTT or PSO-VTT.

1. Figure

Figure 1. Representative Pressio® Monitoring System configuration

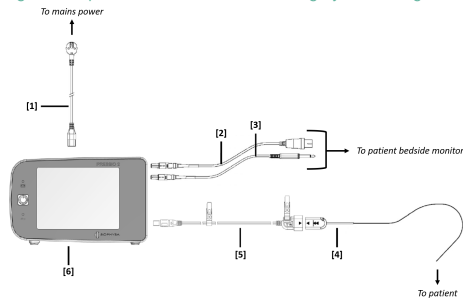

[1] Power cable [2] Pressure cable [3] Temperature cable
[4] Pressio® Catheter [5] Catheter extension cable [6] Pressio® 2 ICP Monitor

2. Introduction

These Instructions for Use detail all the information required for the installation, use and maintenance of the Monitor. They also provide thorough explanations of all information displayed on the screen.

After reading these instructions carefully, the operator will be able to:

- Connect cables
- Connect Catheter
- Zero Catheter

- Monitor the patient
- Access the monitoring history
- Perform basic maintenance

NOTE

The patient is not the expected operator.

For more information, go to www.sophysa.com, or contact Sophysa at contact@sophysa.com, or +33(0)1 69 35 35 00.

3. Intended Use

The Pressio® 2 Intracranial Pressure (ICP) monitor is designed to read and display the pressure values and curves measured by the Pressio® catheters implanted in patients requiring continuous intracranial pressure monitoring.

Depending on the type of catheter used, the Pressio® 2 monitor can also display the intracranial temperature.

With the appropriate Pressio® 2 accessories, the Pressio® 2 monitor also makes it possible to display the ICP curve and the Intracranial Temperature (ICT) value on a patient monitor.

The Pressio® 2 Intracranial Pressure (ICP) monitor is intended for hospital use, particularly in the neuro-intensive care and neurosurgery (operating room) departments.

Patients undergoing ICP (and ICT) monitoring should be subject to strict, continuous monitoring so as to prevent any complications from arising.

NOTE

The Monitor is intended to be used on one patient at a time.

4. Warnings and Precautions

4.1. WARNINGS

- Only use the Monitor with Sophysa-supplied cables, Catheters, and accessories from the Pressio® 2 range of products.
- Do not use the Monitor if there are no trained personnel available to provide continuous observation.
- Do not leave the Catheter in contact with conductive elements, including the ground.
- The Monitor must be correctly grounded to ensure the safety of the patient and the operator. Reliability of the grounding can only be achieved if the Monitor is connected to a ground electrode.
- There is a risk of explosion if used in the presence of inflammable anesthetics.

4.2. PRECAUTIONS

- The patient should only be monitored by trained and qualified personnel.
- Move the patient with care in order to avoid disconnecting any cables, or causing any movement of the implanted Catheter.
- After moving the patient, check the connection of the Catheter to the catheter extension cable, and the connection of the catheter extension cable to the Monitor.
- Do not perform maintenance or service operations during monitoring.
- Do not use a Monitor that is damaged or has fallen. Return it to Sophysa for analysis and repair.
- Do not use the Monitor beyond the period for which its calibration is valid, which is displayed on the calibration label on the bottom panel of the Monitor.
- Do not access the battery when the Monitor is being used on a patient.
- Do not place the Monitor or its cables in an MRI magnetic field.
- Do not use a Monitor and the implanted Catheter at the same time as a high frequency electro-surgical instrument or a defibrillator. The Catheter and/or the Monitor could be damaged or have their operation disrupted.

- The Monitor has been tested and is compliant with the standard IEC 60601-1-2. However, electromagnetic interference could occur in specific situations. If the Monitor causes electromagnetic interference or is subject to it, the user may be able to resolve the situation in the following manner:
 - Power off the Monitor and power it on again.
 - Reorient or move the Monitor in relation to other equipment.
 - Connect the Monitor to a mains power source that is not connected to the other equipment.
 - Contact Sophysa Customer Service at contact@sophysa.com, or contact your local distributor.
- The USB stick can only be used in the patient's environment (within reach of the patient) if it is compliant with one of the following standards: IEC60601-1, IEC60950-1 or IEC62368-1.
- The Monitor has no protection against burns when using HF electrosurgical equipment.

4.3. PRECAUTIONS FOR MONITORING THE PATIENT DURING TRANSPORT

To monitor the patient during transport, disconnect the cables between the Monitor and the patient bedside monitor. The Monitor may be transported with the patient for continuous monitoring during transport without a patient bedside monitor.

The Monitor automatically switches to battery power when it is disconnected from mains power.

NOTICE

Firmly attach the Monitor to the patient's bed during transport to minimize the risk of the Monitor falling, to avoid disconnecting any cables, or causing any movement of the implanted Catheter.

After transport, reconnect the Monitor to the patient bedside monitor using the appropriate cables (temperature and pressure), and then recalibrate the patient bedside monitor.

5. Description

The Monitor is packaged with the following items:

- Pressio® 2 ICP Monitor (PSO-4000)
- Pole clamp (integrated into rear panel)
- Catheter extension cable (PSO-EC30)
- Power cable
- Battery
- Instructions for Use (NT500)
- Screwdriver for opening the battery cover

When unpacking, confirm that package contains all of the above items, and that none of these items has been damaged during shipping.

To monitor the patient's ICP and ICT, the Monitor must be connected to a Catheter (supplied separately) using the catheter extension cable.

The Monitor may be connected to a patient bedside monitor (not supplied by Sophysa) which centralizes the measurements from various medical devices. If the Monitor is connected to a patient bedside monitor, the ICP and ICT measurements are transmitted to the patient bedside monitor via the pressure cable (PSO-MCxx) and the temperature cable (PSO-MCT-y) (supplied separately).

The Monitor must only be used in a professional healthcare facility (intensive care unit, resuscitation room and operating room).

5.1. MONITOR

5.1.1. Front Panel

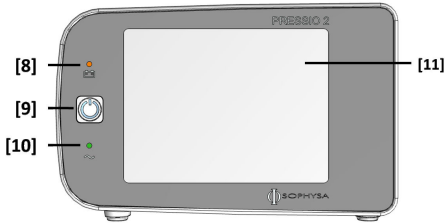

[8] Battery indicator light (orange) [9] Power button
[10] Power indicator light (green) [11] Touch screen

Battery Indicator Light (orange)

When the battery indicator light glows orange, the power cable is disconnected, and the Monitor is operating on battery power.

The battery indicator light flashes when the battery is being charged, or when it is low. To recharge the battery, connect the Monitor to the mains power.

Power button

When the Monitor is off, briefly pressing this button (1 second) powers up the Monitor.

When the Monitor is already on, briefly pressing this button (1 second) places the monitor in standby mode.

When the Monitor is operating on battery power, it is not possible to put it on standby, and pressing this button powers off the Monitor completely.

A long continuous press of this button while powering on accesses menus reserved for maintenance of the machine.

A long continuous press of this button while the Monitor is on will power off the Monitor.

Power Indicator Light (green)

When the power indicator light glows green, the Monitor is operating on mains power.

Touch screen

The back-lit color touch screen displays the ICP and ICT measurements and contains touch keys for configuring the Monitor. Details of these keys are in section *Section 5.4. Screens* (p. 8).

5.1.2. Back Panel

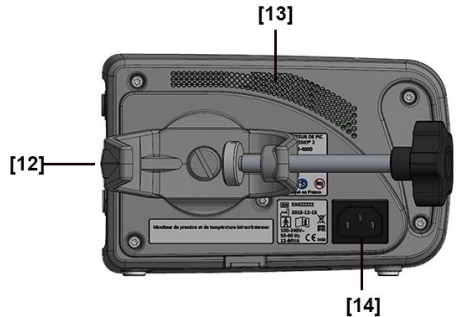

[12] Pole clamp [13] Air vents and loudspeaker [14] Power inlet

Pole clamp

The pole clamp enables the Monitor to be affixed to a vertical pole or a horizontal rail, with a diameter between 10 and 60 mm.

It can be swiveled 360 degrees, in 90-degree increments. To reorient the pole clamp, rotate it in the desired direction until it clicks into position.

WARNING

Do not dismantle the pole clamp as this could impair the electrical safety of the Monitor.

Power inlet

The Monitor should be connected to 100-240 V, 50-60 Hz single phase alternating current mains power with ground, using the power cable provided.

WARNING

Correct grounding can only be ensured if the Monitor is connected to a properly grounded outlet.

5.1.3. Right Panel

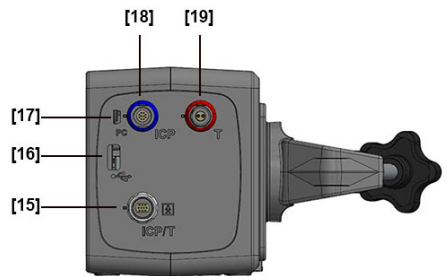

[15] ICP/T Monitoring unit and Catheter extension cable inlet
[16] USB 2.0 port [17] Mini-USB port [18] ICP outlet [19] ICT outlet

Catheter Extension Cable Inlet

The catheter extension cable inlet (white) is used to connect the catheter extension cable, to which the Catheter is connected to the Monitor.

USB 2.0 Port

The USB 2.0 port is used to transfer history data from the Monitor to a USB stick.

Mini-USB Port

The mini-USB port is used to transfer real-time data from the Monitor to a compatible interface.

ICP Outlet

The ICP outlet (blue) is used to connect the Monitor pressure cable to the patient bedside monitor for the transmission of ICP curve.

ICT outlet

The ICT outlet (red) is used to connect the Monitor temperature cable to the patient bedside monitor for the transmission of ICT measurements.

5.2. POWER CABLE

A power cable is supplied with each Monitor.

It is compatible with a 100 V to 240 V mains power, and is packaged with the appropriate plug for the country of destination.

The power cable is plugged into the Monitor using the power inlet on the rear panel. It enables the Monitor to operate on mains power.

WARNING

To avoid any risk of electric shock, the Monitor must only be connected to mains power with protective grounding.

WARNING

Do not allow any of the power connectors to come into contact with liquid.

WARNING

Do not remove the grounding electrode from the circuit.

CAUTION

Electrical isolation of the Monitor is achieved by disconnecting the power cable from the power inlet, on the rear panel of the Monitor. Do not position the Monitor so that it is difficult to unplug the power cable.

5.3. CATHETER EXTENSION CABLE

The catheter extension cable is used to connect the Catheter to the Monitor. It transmits the Catheter measurements to the Monitor, in the form of analog signals.

It is supplied with every Monitor and is also available separately. It is 2 meters long.

It is only compatible with the Pressio® 2 ICP Monitor.

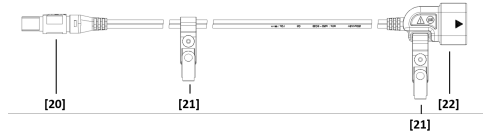

[20] Plug [21] Fixation clips [22] Dongle inlet

The plug (20) attaches to the Monitor. A guide pin and color code (white) facilitate proper connection.

The fixation clips (21) attach to the bed sheets, or to the patient's clothing. Proper use of these clips limits traction on the implanted Catheter, and reduces the risk of Catheter disconnection.

The dongle inlet (22) attaches to the Catheter. A guide pin and color code (blue arrows) facilitate proper connection.

CAUTION

Do not allow any connectors to come into contact with liquid.

5.4. SCREENS

The Monitor screen has three distinct data presentation areas: the status bar (A), the physiological display (B) and the action bar (C).

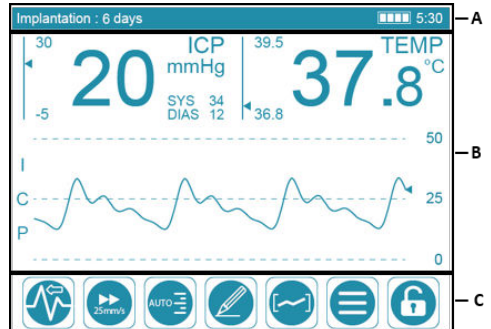

5.4.1. Status Bar



The status bar displays:

– The duration of implantation (D) of the Catheter.

NOTE

The text flashes when the duration of implantation reaches or exceeds 6 days (144 hours).

– The alarm status (E) if the alarm is deactivated.

– The battery charge status (F).

– An estimation of the remaining battery life (G).

The meaning of the battery charge icons is as follows:

Display	Description
	The battery is at 100% capacity.
	The battery is at 75% capacity.
	The battery is at 50% capacity.
	The battery is at 25% capacity.
	If the Monitor is operating on battery power: quickly connect the Monitor to mains power (15 minutes of operation remaining). If the Monitor is operating on mains power: the battery is being charged, at least 25% capacity.
	Immediately connect the Monitor to mains power (1 minute of operation remaining).
	The battery temperature is excessive. If operating on batteries, the Monitor stops 10 seconds after the appearance of this icon. If operating on mains power, the battery stops charging.
	The battery is not connected or must be changed.

NOTE

With a fully charged battery, the Monitor can operate for approximately 6 hours, in normal operation.

5.4.2. Physiological Display

5.4.2.1. Intracranial Pressure (ICP)



The ICP alarm thresholds (H) are displayed to the left of the mean ICP value (I).

The monitor prominently displays the mean ICP value (I) as well as the systolic (J) and diastolic (K) pressures in millimeters of mercury (mmHg).

1 mmHg corresponds to 13.6 mmH₂O and to 133 Pa.

NOTE

If there is no difference between the systolic and diastolic values, the Monitor displays “---” in front of SYS and DIAS.

5.4.2.2. Intracranial Temperature (ICT)



The ICT alarm thresholds (L) are displayed to the left of the ICT value (M).

When the implanted Catheter includes a temperature sensor, the Monitor displays the ICT value (M).

The intracranial temperature can be displayed in degrees Celsius (°C) or degrees Fahrenheit (°F).

5.4.2.3. ICP Curve



The ICP curve (N) updates in real time, and its display may be adjusted using the and buttons in the action bar.

The ICP curve scale (O) is displayed to the right of the ICP curve.

5.4.3. Action Bar



The action bar provides access to display options and configuration menus.

It locks automatically after 5 minutes of inactivity to prevent accidental entry to the menus by touching the touch screen and changing the parameters. When the action bar is locked, only the button is visible and accessible.

As soon as an alarm occurs, the action bar unlocks automatically, to allow access to all of the various action bar buttons.





NOTE

The , , and buttons function as drop-down lists. Pressing any of these displays additional options.

5.4.3.1. Scrolling mode for the ICP curve

To change the scrolling mode, press the button and select an option from the following:

Display	Description
	Rapid refreshing of the ICP curve, by erasing from left to right.

Display	Description
	Rapid scrolling of the ICP curve from right to left.
	Hiding of the ICP curve from the screen.
	Slow scrolling of the ICP curve from right to left. In this mode, the speeds offered by the  button are suitable for slow scrolling. The display of a new ICP curve takes place 10 minutes after the start of monitoring. During this time the button is greyed out and not functional.

5.4.3.2. Scrolling Speed for the ICP curve

When the ICP curve is displayed on the screen, the  button enables changes to the scrolling speed of the ICP curve.

To change scrolling speed, press the  button and select speed from the other settings available.

NOTE

When the MEAN scrolling mode is activated, other values are displayed suggesting slower scrolling.

The scrolling speeds are expressed in millimeters per second (mm/s) or in centimeters per hour (cm/h).

5.4.3.3. Pressure Scale for the ICP curve

When the ICP curve is displayed on the screen, the  button enables changes to the scale for the height of the curve.

To change the pressure scale, press the  button, and select a scale from the settings available.

The pressure scale intervals are expressed in millimeters of mercury (mmHg).

Select the AUTO option to obtain the pressure scale setting most suitable for the values measured among the settings available.

5.4.3.4. Event Entry

Press the  button to display a virtual keyboard, and to enter an event.

Each event has a maximum length of 50 characters. It is dated and added to the history.

The entered events cannot be changed or erased.

To add more information to an existing event:

1. Enter the history mode.
2. Place the cursor close to the event already created.
3. Add a new event.

5.4.3.5. Access to the History

Press the  button to consult the history of the monitoring in progress.

5.4.3.6. Access to other configuration settings

Press the  button to access the following settings:

Display language

Press “Language” to change the language used on the screen.

Alarms

Press “Alarm” to access alarms activation/deactivation and alarm thresholds limits for ICP and ICT.

Recording modes

Press “Recording mode” to manage the history recording modes.

Degrees Celsius or Fahrenheit

Press “Parameters”, then “Temperature unit” to change the units used for displaying temperature (C° or F°).

Time zone

Press “Parameters” then “Time Zone”, to select the time zone where the Monitor is to be used.

Screen brightness

Press “Parameters”, then “Brightness” to adjust the screen brightness.

5.4.3.7. Locking and Unlocking the Action Bar

Press and hold the  button to unlock the action bar and to access the configuration settings menu.



The action bar re-locks:

- by pressing the  button,
- automatically after 5 minutes of inactivity.

5.4.3.8. Temporary Audible Alarm Suspension

The  button appears automatically when an alarm is triggered.

Press this button to suspend audible alarms temporarily. Audible alarms reactivate automatically after 2 minutes.

When audible alarms are suspended, the  button is replaced by the following button in the bottom right corner of the touch screen: 

Audible alarms can be reinitialized by changing the value of one of the ICP or ICT alarm thresholds, or by deactivating and reactivating the physiological alarms.

5.4.4. Alarms

The physiological alarms trigger when the ICP and/or ICT values exceed the alarm thresholds set.

Depending on the specific clinical situation, the ICP and ICT alarms may trigger simultaneously or independently.

NOTE

Stand right in front of the Monitor touch screen for proper alarm readability.

The Monitor manages two alarm priority levels, depending on the physiological parameter alarming:

- ICP: High clinical priority - Fast response time
- ICT: Moderate clinical priority - Delayed response time

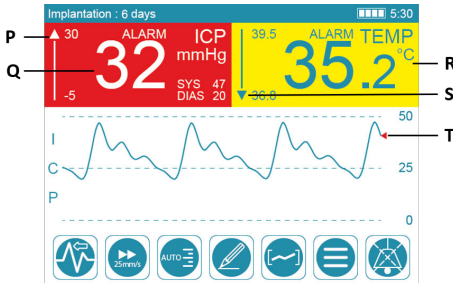

When the ICP alarm threshold is triggered, the mean ICP value flashes on a red background (Q). The cursor (T) for the ICP curve also becomes red.

When the ICT alarm threshold is triggered, the ICT value flashes on a yellow background (R).

When either physiological alarm is triggered, the cursor of the alarm threshold gauge places itself:

- above the gauge (P) if the alarm thresholds are exceeded upwards,
- below the gauge (S) if the alarm thresholds are exceeded downwards.

The visual alarms are accompanied by an audible alarm, which may be deactivated for 2 minutes by pressing the



For more information on physiological alarms, see Section 5.4.3.8. *Temporary Audible Alarm Suspension* (p. 10).

NOTE

If an alarm threshold is briefly exceeded, the visual alarm may still be flashing, although the value has returned to within the set limits. This visual alarm will disappear after 30 seconds.

6. Initial Installation

6.1. INSTALLING THE BATTERY

For added safety, the battery is not pre-connected to the Monitor, and must be installed, prior to use.

Follow these steps to install the battery:

1. Remove screw (23) using the supplied screwdriver to open the battery cover, located on bottom panel of the Monitor.



2. Remove the tie and label from the battery connectors.
3. Insert battery as shown in the picture and connect the mated battery connectors (24) until a click is heard.



4. Replace battery cover, and tighten screw (23).

6.2. CONFIGURING THE TIME ZONE

NOTE

Configuring the time zone and setting summer time (Daylight Saving Time) or winter time (Standard Time) are necessary for accurately dating the measurements, which are recorded in the history.

Follow these steps to configure the time zone:

1. Connect the Monitor to mains power using the power cable.
2. Press the power button.
The battery indicator (orange) and power indicator (green) lights on the front panel of the Monitor will glow simultaneously for 4 seconds. The Monitor then emits a series of 3 beeps.

WARNING

If either of the indicators does not glow, or if the Monitor does not emit 3 beeps when starting, disconnect the Monitor and contact Sophysa Customer Service at contact@sophysa.com, or contact your local distributor.

The touch screen lights up, and the time zone options appear:

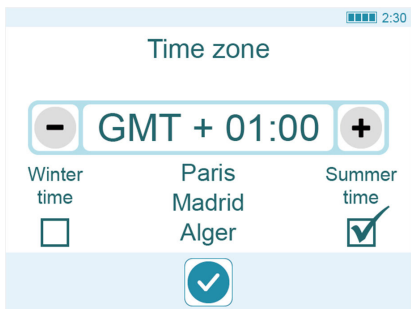

3. Select the time zone for the location of use.
4. Specify which time system (summer or winter) is in effect when the Monitor is being put into service.
5. Confirm time zone by pressing the  button.

With the battery installed, and the time zone options selected, the touch screen displays a flashing message inviting you to connect the Catheter.

The Monitor is now ready to use.

NOTE

For maximum battery life, first operate the Monitor on mains power for several hours, until battery charge indicator light appears near the right end of the status bar, at top right corner of the Monitor touch screen:



7. Setting-up the System

7.1. EQUIPMENT VISUAL CHECK

Make sure that the Monitor, accessories and cables are clean and in correct mechanical condition.

WARNING

Do not use the Pressio® Monitoring System if you detect any defect, such as cracks, frayed cables or broken connectors, on the Monitor or its cables or accessories.

7.2. POSITIONING THE SYSTEM

Position the Monitor horizontally, using the pole clamp to prevent any forward tilting. If the Monitor must be placed on a surface, make sure the surface is flat.

8. Cleaning and disinfection procedures

CAUTION

Do not use the Monitor, its cables or accessories if there is any soiling or visible residues on the external surface of the components or inside the cable wires.

1. Power off the Monitor. If the Monitor is operating on mains power, unplug it as well.
2. Disconnect all the cables and USB devices from the Monitor.

NOTICE

Avoid any contact with the connectors on the right panel of the Monitor.

8.1. INTRODUCTION

The Monitor and the cables are delivered clean, but not disinfected.

Clean the Monitor and all its cables before first use and between each patient, as described here. Then disinfect the Catheter Extension Cable.

CAUTION

Use the pole clamp to immobilize the Monitor during monitoring and patient transport, to prevent an accidental fall of the Monitor, and possible traction on the catheter extension cable and the implanted Catheter.

WARNING

Do not clean the Monitor or the Catheter, nor disinfect the cables, when in use on the patient.

WARNING

Do not immerse, autoclave or soak the Monitor or its accessories in a liquid. Their performance (including drift and electrical safety) could be affected.

WARNING

Catheter kits are supplied **sterile, for single use only**. Do not reuse a Catheter.

WARNING

Do not re-sterilize a Catheter, or re-use it after opening the packaging, and/or after explantation.

For more information, refer to the Instructions For Use (IFU) of the Catheter being used.

NOTICE

Do not use solvents or cleaning agents which could damage the Monitor casing and the cables, such as:

- cleaning/disinfection agents based on phenols,
- cleaning/disinfection by boiling,
- cleaning/disinfection by hot air/steam,
- acetone, ammonia, benzene, bleaching agent, chlorine, chlorine water, water above 60°, paint solvents, trichloroethylene.

For more information, contact Sophysa Customer Service at contact@sophysa.com, or contact your local distributor.

8.2. PREREQUISITES

1. Put on gloves and keep them throughout the procedure.
2. Take pre-soaked wipes with 70% isopropyl alcohol (IPA).

8.3. CLEANING PROCEDURE

The purpose of this procedure is to remove any soiling and visible residues on the external surfaces of the Monitor, including the touchscreen, its cables and accessories.

NOTE

Do not put excessive pressure on the product labels.

1. Clean the components for at least 1 minute using pre-soaked wipes with 70% isopropyl alcohol (IPA), to remove any visible residues.
Change the wipe between each component.
 - a. Carefully wipe the touch screen without excessive pressure.
 - b. Thoroughly wipe the external surfaces of the Monitor and the cables.
2. Inspect the components.
If residues remain, take a new pre-soaked wipe with 70% isopropyl alcohol (IPA) and wipe the surfaces again.

NOTE

Repeat this step until all visible residues are removed from all components.

Let the components completely air dry for 1 hour before using them again.

3. Disinfect the Catheter Extension Cable as described in the following section.

8.4. DISINFECTION PROCEDURE

The purpose of this procedure is to remove any microorganisms present on the Catheter Extension Cable.

1. Thoroughly wipe the Catheter Extension Cable. It must remain visibly wet for at least 2 minutes.
If needed, use additional wipes to ensure continuous 2 minutes of wet contact time.
2. Let the Catheter Extension Cable completely air dry for 1 hour before using it again.

8.5. INSPECTION

After each cleaning or disinfection procedure, visually inspect the components for any damage.

Check the visual aspect of the cables before use.

Make sure that:

- there is no foreign body in the cable plug,
- electrical connections of the plug are not twisted,
- there are no visible cracks on the cable,
- cable markings are still visible.

The cables have an expected lifetime of 2 years in normal use (disconnecting and reconnecting between each monitoring). However, the results of the visual checks listed above prevail. These visual checks will indicate whether or not the cables can still be used.

9. Operating Information

CAUTION

The Monitor should only be used by trained and qualified personnel.

CAUTION

The implantation of the Catheter should be performed **immediately** after the Catheter is zeroed. It is therefore essential to prepare for the implantation of the Catheter, by referring to the Instructions for Use of the Catheter kit to be used, before using the Monitor.

CAUTION

Prior to each patient, inspect the Monitor casing and all the cables to ensure none of these components are damaged.

CAUTION

If a message indicating a low battery level displays on the touch screen when powering on, connect the Monitor to mains power.

WARNING

Catheters and the catheter extension cable are not protected against defibrillation and may be damaged as a result.

Before defibrillation:

- Disconnect the catheter extension cable from the Catheter.
- Withdraw the Catheter, if possible. If this is not possible, for safety reasons, replace the Catheter after defibrillation to continue monitoring.

Frequently used features

Frequently used features of the Monitor include the following:

- Display of the mean ICP value, and systolic and diastolic ICP values. See *Section 5.4.2.1. Intracranial Pressure (ICP)* (p. 9).
- Display of the ICP curve. See *Section 5.4.2.3. ICP Curve* (p. 9).
- Display of the ICT value. See *Section 5.4.2.2. Intracranial Temperature (ICT)* (p. 9).
- Presentation of ICP and ICT visual and audible alarms, and suspension of the audible alarms. See *Section 5.4.4. Alarms* (p. 10).
- Display of messages in the user-selected language. See *Section 5.4.3. Action Bar* (p. 9).
- Display of the battery charge status. See *Section 5.4.1. Status Bar* (p. 8).

9.1. CONNECTING CABLES

The catheter extension cable and the pressure and temperature cables are fitted with guide pins, to facilitate proper connections.

To **attach** any of these cables:

1. Align the arrows on the connector tip with the mark [25] of the inlet (or outlet), on the Monitor right panel.

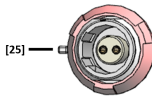

2. Push the connector in. It should enter easily without forcing.

To **disconnect**, slide the connector envelope away from the inlet (or outlet), and pull the connector from the inlet (or outlet).

9.2. POWERING ON THE MONITOR

WARNING

The Monitor performs a self-test when powering on. During this self-test, the battery indicator and power indicator lights glow and the speaker emits 3 beeps. If the indicator lights do not glow, or if the speaker does not emit 3 beeps, disconnect the Monitor and contact Sophysa Customer Service at contact@sophysa.com, or contact your local distributor.

Power on the Monitor as follows:

1. Affix the Monitor to a pole or rail.
2. Connect the power cable to the power inlet of the Monitor.
3. Connect the power cable to mains power.
4. Press the power button.

The battery indicator (orange) and the power indicator (green) lights on the front panel of the Monitor glow simultaneously for 4 seconds. The Monitor then emits a series of 3 beeps, and the touch screen displays a message instructing the user to connect the Catheter.

Auto-calibration of the Screen

The touch screen auto-calibrates when the Monitor powers on. Do not touch the screen during this auto-calibration.

9.3. ZEROING THE CATHETER

Zeroing the Catheter involves calibrating the catheter in relation to atmospheric pressure.

WARNING

Perform the zeroing procedure on each new Catheter, **before** implanting it in the patient.

CAUTION

Observe aseptic technique throughout the entire zeroing procedure.

NOTICE

Do not allow the catheter extension cable connector to come into contact with liquid.

NOTE

The intracranial temperature sensor is calibrated in the factory. Therefore, the temperature setting does not need prior zeroing.

Consult the Instructions for Use supplied with the Catheter kit. These instructions contain additional information on the precautions to be taken with the Catheter.

9.3.1. Prerequisites

- Power on the Monitor.
- Connect the catheter extension cable to the Monitor.
A message inviting you to connect the Catheter displays on the Monitor screen.

9.3.2. Procedure

1. Unpack the Catheter (sterile) within the sterile field.
2. Prepare a shallow cup of sterile saline solution (less than 5 mm).

CAUTION

Using a deep receptacle could lead to hydrostatic pressure greater than atmospheric zero, which would then lead to an erroneous reference zero.

3. Observing aseptic technique, connect the catheter extension cable (non-sterile) to the Catheter, aligning the blue arrow on the Catheter dongle [26] with the blue arrow on the catheter extension cable connector [27].

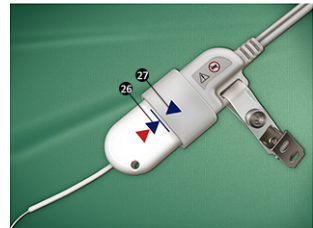

The Catheter dongle must be completely inserted into the catheter extension cable connector. A blue line on the Catheter dongle indicates the point of complete insertion.

4. Within the sterile field, immerse the sensor (metal tip) of the Catheter [28] in the cup of sterile saline solution [29], without touching the cup.

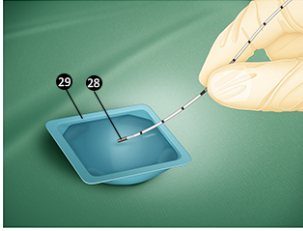

CAUTION

Avoid any contact with the sensor during zeroing procedure. Calibration in relation to atmospheric pressure could be falsified.

CAUTION

Keep the sensor immersed in sterile saline solution during the zeroing procedure. Zeroing the sensor in conditions other than those recommended may cause inaccurate pressure readings.

- While the sensor is immersed, press the Zero button on the Monitor touch screen .

Zeroing the Catheter requires approximately 4 seconds. Do not move the sensor during the zeroing procedure.

- If the zeroing procedure is successful, the Monitor touch screen displays a message indicating that the Catheter is ready to be implanted.
- If the zeroing procedure is not successful, follow the instructions displayed on the Monitor touch screen.

NOTE

Zeroing the Catheter can only be performed once. Upon completion, the zero calibration information is stored in the Catheter dongle. It allows the Catheter to be disconnected from a Monitor, and re-connected to any Monitor, without losing the zero calibration information.

9.4. IMPLANTING THE CATHETER

Refer to the Instructions for Use of the Catheter kit being used.

Once the Catheter is implanted, the Monitor displays the mean ICP value in millimeters of mercury (mmHg).

After the first 24 hours, the Monitor also displays the duration of the Catheter implantation in the form of the message “**Implantation: X days**”, at the top left corner of the touch screen, for the entire duration of its implantation.

CAUTION

Catheters are recommended to be implanted for up to 6 days (144 hours). When this duration is exceeded, the message “**Implantation: X days**” flashes at the top left corner of the touch screen and the accuracy of the displayed ICP value is no longer guaranteed.





9.5. ACTIVATING OR DEACTIVATING THE PHYSIOLOGICAL ALARMS

The Monitor generates two types of visual/audible alarms:

- Physiological alarms, to warn the personnel that the mean ICP and/or the ICT have exceeded the set alarm thresholds.
- Technical alarms, to warn the personnel that there is a problem with the Monitor or the Catheter.

The specifications for the technical alarms are explained in Section 18. *Technical Specifications* (p. 22), at the end of this document.

To activate or deactivate the physiological alarms:

- If necessary, first unlock the touch screen by pressing and holding the  button.
- Press the  button.
- Press “Alarm”. The alarm settings screen displays.
- Select:
 - ON to activate the alarms.
 - OFF to deactivate the alarms.
- Press the  button to return to the selection menu.
- Press the  button to return to monitoring.



When the ICP and ICT visual and audible alarms are deactivated, this symbol , followed by the note “ALARM OFF” appears in the status bar:  ALARM OFF.

9.6. ADJUSTING ALARM THRESHOLDS

CAUTION



The alarm thresholds should only be adjusted by a trained and qualified personnel.

To adjust the alarm thresholds:

- If necessary, first unlock the touch screen by pressing and holding the  button.
- Press the  button.
- Press “Alarm”. The alarm settings screen displays.
- Press [-] or [+] to adjust the alarm thresholds.

NOTE

Specifying an alarm threshold in a greyed-out area is not possible.

- Press the  button to return to the selection menu.
- Press the  button to return to monitoring.

The temperature alarm thresholds can be set between 20 °C and 45 °C (68 °F and 113 °F), in increments of 0.1 °C or °F.

The pressure alarm thresholds can be set between -10 mmHg and 40 mmHg, in increments of 1 mmHg.

CAUTION

ICP and ICT alarm thresholds must be set so that physiological alarms can be triggered.

9.7. CONNECTING AND CALIBRATING THE PATIENT BEDSIDE MONITOR

WARNING

Only connect the Monitor to patient bedside monitors which are compliant with IEC 60601-1, and marked "BF" or "CF" or bearing the international symbols:



Once the Catheter is implanted, and the first measurements have been displayed on the Monitor, connecting the Monitor to the patient bedside monitor allows the ICP and ICT values to be displayed along with other physiological parameters on the patient bedside monitor.

NOTE

If the patient bedside monitor has not been calibrated, the Monitor sends a warning value of 360 mmHg to the patient bedside monitor. The patient bedside monitor may then display the value "360" or another pressure over range message.

1. Connect the Monitor to the patient bedside monitor using the pressure cable (PSO-MCxx) and temperature cable (PSO-MCT-y) specific to the patient bedside monitor.

CAUTION

Check the proper connection of the pressure cable carefully before the patient bedside monitor calibration procedure.

The Monitor automatically detects the connection to the patient bedside monitor and displays the following message: **Sending 0 mmHg signal to patient monitor.**

2. On the patient bedside monitor, press the zero (0) key relating to the ICP parameter (refer to the documentation for the patient bedside monitor being used).
3. Check that the patient bedside monitor displays 0 mmHg, then return to the Monitor touch screen and press . The following message displays: **Sending 30 mmHg signal to patient monitor.**

WARNING

During the sending of the 30 mmHg signal, do not press the zero (0) key on the patient bedside monitor.

4. On the patient bedside monitor, wait until the measurement stabilizes (approximately 30 seconds) and check that the value displayed is 30 mmHg.

NOTE

Because of the calculation methods and rounding, the patient bedside monitor can display a value which is different than the value displayed on the Monitor. For the 30 mmHg calibration, displayed values between 29-31 on the patient bedside monitor are acceptable.

If the values displayed on the patient bedside monitor are outside of this range, two solutions are possible:

- adjust the patient bedside monitor gain so that it displays the desired value,
- read the difference in values and take it into account when adjusting the alarm thresholds on the patient bedside monitor.

5. If the patient bedside monitor displays 29, 30 or 31 mmHg, return to the Monitor touch screen and press



The following message displays: **Sending 60 mmHg signal to patient monitor.**

WARNING

During the sending of the 60 mmHg signal, do not press the zero (0) key on the patient bedside monitor.

6. On the patient bedside monitor, wait until the measurement stabilizes (approximately 30 seconds) and check that the value displayed is 60 mmHg.
For the 60 mmHg calibration, displayed values between 58-62 on the patient monitor are acceptable. Outside these values, apply one of the two solutions described previously in the Note in step 4.
7. When the patient bedside monitor displays values between 58 and 62 mmHg, return to the Monitor touch screen and press  to return to monitoring.

9.7.1. Repetition of the Patient Bedside Monitor Calibration Procedure

The patient bedside monitor calibration procedure may be repeated, if necessary, in the following situations:

- Powering off of the Monitor or the patient bedside monitor.
- Disconnection of the pressure cable between the Monitor and the patient bedside monitor.

9.7.2. Alarm Thresholds

The alarm thresholds selected within the Monitor are not acquired by the patient bedside monitor. They must be set directly on the patient bedside monitor.

9.7.3. Temperature

The ICT measurement is detected by the patient bedside monitor as soon as the temperature cable is connected. It does not need calibration.

9.8. CHANGING THE MONITOR

The Catheter zeroing information is stored in the Catheter dangle. Once the Catheter is implanted, it can be disconnected from and then reconnected to the same Monitor, or

reconnected to a different Monitor, without needing to repeat the catheter zeroing process.

10. Advanced Functions

10.1. HISTORY

NOTE

The cumulative memory for the history is 15 days. Beyond 15 days, the history data will be deleted on a first-in, first-out (FIFO) basis.

For example, the data for the 16th day will delete the data for the first day. The data for the 17th day will delete that for the 2nd day, etc.

NOTE

Avoid changing the time settings (summer time to winter time) during monitoring. This change results in new history data being dated with the new time, and no longer aligning with the history data recorded before the time settings change.

NOTE

When a new Catheter is connected, the Monitor may delete automatically previous recordings from its internal memory.

Pressing the  button opens the history screen, along with the history physiological display and the history action bar.

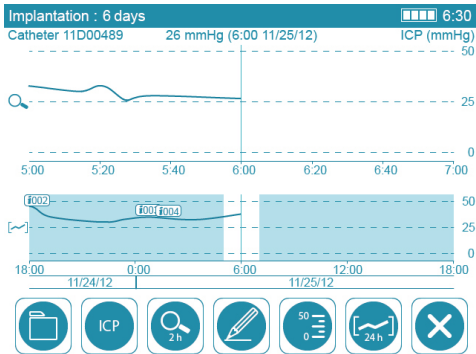



This screen displays the record of the monitoring in progress.

To scroll through this record, slide the curve to the left or right, using a finger on the touch screen.

10.1.1. File management

See Section 10.2. *Data Transfer* (p. 18) for more information on the  button.

10.1.2. ICP or ICT

Press the  default button, and press either the  or  button to select the history data record to display: ICP or ICT.

10.1.3. Zoom

Press the  button to select a different zoom value, or to deactivate the zoom.

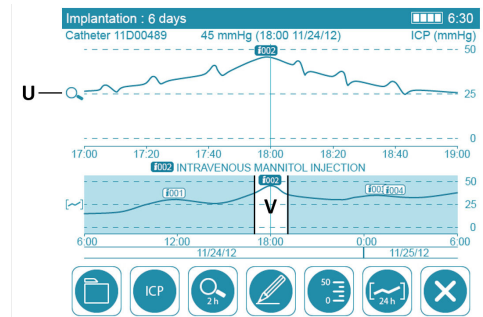

The enlarged section is located in the upper portion (U) of the physiological display. It corresponds to the zoom interval (V) of the complete history curve, located in the lower portion of the physiological display.

10.1.4. Event Bubbles



On the history curve, event records are shown in event bubbles, represented by numbers attached to the curve (for example: i002).

To display the contents of an event bubble, scroll the curve until the cursor (vertical line in the center) touches the event bubble. The contents display in the middle of the physiological display, between the two curves.

10.1.5. ICP Pressure Scale

Press the  button to adjust the range, in mmHg, of the pressure scale for the curves.

10.1.6. Period

Press the  button to adjust time, in minutes, hours or day, for the period displayed.

10.2. DATA TRANSFER

Press the  button to access the various options for importing and exporting history files. The procedures differ depending on the desired operation.

NOTE

PDF files cannot be read on the Monitor.

On the other hand, exported .csv files are encrypted, and can only be read on the Monitor.



NOTE

To import or consult files from a USB stick on the Monitor:

- Do not rename or change the format of the history files.
- The history files must be located in the root directory of the USB stick.



The Monitor only recognizes USB sticks in FAT32 format.

NOTE

During the import or export of history data, it is possible to return to the monitoring screen. The  button is replaced by a wait symbol  until the end of the data import or export.

During the import or export of history data, the external USB stick must not be disconnected while the wait symbol  is present.

10.2.1. Exporting a History to a USB Stick



1. Connect a USB stick to the USB 2.0 port, on the right panel.
2. From the list of history files, select the file from either list "Internal Historical Records" or "Catheter History".
3. Press the  default button, and select the export format:
 - : exports the average ICP and ICT values and creates a PDF file.
 - : exports all real time measurements for ICP values, and the average values for ICT.

4. Press .

10.2.2. Exporting a History from a Catheter Dongle to a USB Stick

1. Connect a USB stick to the USB 2.0 port, on the right panel.
2. Select the file from the list "Catheter History".
3. Press **[SAVE DONGLE]**.

10.2.3. Importing a History from a USB Stick

1. Connect a USB stick to the USB 2.0 port, on the right panel.
2. Press the  button.
3. Select the file from the list "USB-stick historical records".
4. Press:
 -  to consult the history (without being able to change it).
 -  to import the history, which allows for the new measurements to be added to the history file.

10.2.4. Consulting a History from the Monitor Internal Memory

1. Select the file from the list "Internal Historical Records".
2. Press .

10.3. DATA ACQUISITION

The mini USB port makes it possible to obtain raw data from the Catheter in the form of ASCII values, to analyze them with third-party software (not supplied by Sophysa).

These analyses are typically conducted for research purposes.

The data flow specifications are available on request. For more information, contact Sophysa at contact@sophysa.com.

NOTE

If a computer is connected to the Monitor, for data acquisitions, that computer must be compliant with one of the following IEC standards: 60601-1, 60950-1 or 62368-1.

11. Environmental Conditions, Storage and Shipping

11.1. ENVIRONMENTAL CONDITIONS

The Monitor and its accessories are designed to withstand the following environmental conditions:

- Temperature: between +10 °C (50 °F) and +40 °C (104 °F).
- Relative humidity without condensation: between 15% and 95%.
- Altitude: between -500 m and +3,000 m (corresponding to a flight altitude up to 12,000 m in a pressurized cabin).

11.2. STORAGE

Store the Monitor with its battery charged to at least 50%.

NOTICE

Disconnect the battery when storing the Monitor for an extended period, or when transporting it by plane.

The Monitor and its accessories are designed to withstand the following storage conditions:

- Temperature: -20 °C (-4 °F) and +60 °C (140 °F).
- Relative humidity: between 5% and 95%.
- Altitude: between -500 m and +4,600 m (corresponding to a flight altitude up to 12,000 m in a pressurized cabin).

11.3. SHIPPING

Protect the Monitor and its accessories from shocks and vibrations during shipping.

The Monitor and its accessories are designed to withstand the following shipping conditions:

- Temperature: -20 °C (-4 °F) and +60 °C (140 °F).
- Relative humidity: between 5% and 95%.
- Altitude: between -500 m and +4,600 m (corresponding to a flight altitude up to 12,000 m in a pressurized cabin).

12. Equipment inspection

Once you have received the equipment and between each patient, perform a visual inspection and run power-up tests before servicing the unit.

Clean the unit every 2 years, as well as each time the unit is serviced. See section *Cleaning and disinfection procedures*.

NOTE

If you identify any defect with the monitoring system or one of its cables, return the device to Sophysa for proper investigation.

12.1. VISUAL INSPECTION

To properly inspect the Monitor and all the cables available, check the following points:

1. Is the unit damaged?
Are there any cracks in the housing?
2. Is the display cracked or damaged?
Does it have major scratches or abrasions?
3. Is the white input connector (ICP/T) clean and undamaged?
4. Is the blue input connector (ICP) clean and undamaged?
5. Is the red input connector (T) clean and undamaged?
6. Is there any loose part in the housing (battery cover, connector, pole clamp or any other part)?
7. Is the power cable free of cracks, cuts or broken wires?
Check the bend relief.
8. Is the pole clamp properly working?
You can tighten and rotate it.
9. Are all the labels and markings complete and readable?
10. Is the Catheter Extension Cable free of cracks, cuts or broken wires?
Check the bend relief.

11. Is the Pressure Cable free of cracks, cuts or broken wires?
Check the bend relief.
12. Is the Temperature Cable free of cracks, cuts or broken wires?
Check the bend relief.
13. Are the cable plug, Monitor connectors and air vents free of foreign body?

For points 1, 2, 3, 4, 5, 6, 9: return the Monitor to Sophysa, as no repairs are allowed.

For points 7, 8, 10, 11, 12: replace the faulty part.

NOTICE

Any unauthorized attempt to repair the equipment under warranty voids that warranty immediately.

12.2. POWER-UP TESTS

Press the power-on button of the Monitor (without connecting the catheter).

During the 4s of power-up, check the following points:

1. All the LED indicator lights are on (green and orange).
2. The Sophysa logo is readable and displayed along with the model and software revision number.
3. You can hear 3 sounds:
 - Sound 1: first notes of high priority alarm sound test.
 - Sound 2: key bip test.
 - Sound 3: medium priority sound test.
4. At the end of the power-up, the Monitor displays the screen **Connect Catheter**.

If any of these checking points fails, return the Monitor to Sophysa. No repairs are allowed.

13. Maintenance

13.1. PREVENTIVE MAINTENANCE

Sophysa recommends continuous vigilance to ensure that the Monitor, its cables and accessories are in good operating condition for every new patient.

Charge the battery no less frequently than every 2 months, to preserve the battery service life.

CAUTION

The Pressio® Monitoring System does not have any components which can be repaired by the user.

If any part of a Pressio® Monitoring System requires repair work, do not attempt to repair locally.

Any additions or modifications made to the Monitor may compromise its performance and will cancel the warranty.

For more information, contact Sophysa Customer Service at contact@sophysa.com

13.2. MAINTENANCE

Return the Monitor, its accessories and cables to Sophysa every 24 months for maintenance, including calibration verification.

Contact Sophysa Customer Service at contact@sophysa.com to organize the shipment of your equipment.

NOTE

Sophysa cannot guarantee that the Pressio Monitoring System will function as intended if the maintenance of the monitors has not been carried out by Sophysa or by a third party duly authorized by Sophysa.

NOTE

Sophysa does not accept any responsibility if a Monitor is used beyond its valid maintenance period and/or if maintenance has not been performed by Sophysa, or by a third party duly authorized by Sophysa, even if the Monitor has been used with the correct, warranted accessories.

14. Recycling

The Monitor must be properly recycled or destroyed in accordance with local regulations.

To avoid any contamination, or infection of personnel, the environment or equipment, correctly disinfect and decontaminate the Monitor before discarding or recycling it.

The Monitor contains:

- one lithium button cell,
- one lithium ion battery.

The electronic components may contain environmental hazards, such as condensers. They should be recycled or destroyed in compliance with local regulations relating to electronic waste.

15. Warranty







The performance of the Monitor is only warranted with Catheter kits and accessories designed, tested and manufactured by Sophysa.









Sophysa warranties that the Monitor is free of any material and manufacturing defects. Apart from this warranty, Sophysa does not provide any other warranty, express or implicit,







including commercialization or adaptation for a particular use. Sophysa cannot be held responsible for any incident, complication, damage or prejudice occurring directly or indirectly from the use of this device. Sophysa does not authorize anyone whomsoever to take responsibility on its behalf for its products.

16. Symbols

16.1. MONITOR



Symbol	Meaning
	Catalog reference
	Serial number
	Lot number
	Manufacturer
	Date of manufacture
	Refer to the Instructions for Use
	Consult the Instructions for Use

Symbol	Meaning
	CE Conformity Marking
	Date of recalibration
	The Monitor must only be used with Sophysa cables, Catheter kits and accessories from the Pressio® 2 range.
	Do not connect the Monitor to patient bedside monitors that are not labelled either "BF" or "CF".
	MR unsafe. The Monitor is not for use in an MRI environment. Do not use during an MRI examination.
	Discarding this type of product with other waste is prohibited.
	Fuse
	Alternating current



Symbol	Meaning
	CF TYPE EQUIPMENT: Providing an appropriate degree of protection against electric shock, having a Type CF insulated applied section (floating), designed for direct cardiac application.
	BF TYPE EQUIPMENT: Providing an appropriate degree of protection against electric shock, having a Type BF insulated applied section (floating).
	Temperature limits
	Pressure limits
	Humidity limits
	Keep away from liquids

Symbol	Meaning
	Fragile, handle with care

16.2. CATHETER EXTENSION CABLE

Symbol	Meaning
	The catheter extension cable is not protected against the effects of a cardiac defibrillator.
	MR unsafe. The catheter extension cable is not suitable for use in an MRI environment. Do not use during an MRI examination.

16.3. CATHETERS

Sym- bol	Meaning
	The Catheters are not protected against the effects of a cardiac defibrillator.
	MR Conditional. It has been demonstrated that the use of the Catheters within an MRI setting does not pose any risks as long as the specific conditions of use are complied with. These conditions of use are detailed in the Instructions for Use for each Catheter.

17. Troubleshooting

17.1. HELP FUNCTION

The Monitor incorporates a “Help” function.

When certain operating anomalies occur, a flashing  button displays at the right end of the action bar.

To access potential solutions, press the  button.

Follow the instructions shown on the touch screen in order.

If the problem persists, contact Sophysa Customer Service at contact@sophysa.com or contact your local distributor.

17.2. ERROR CODES

If the “Help” function is not accessible, refer to the following troubleshooting table:

SYMPTOMS	POSSIBLE CAUSES	SUGGESTED ACTIONS
Monitor and patient bedside monitor pressuring readings do not match.	Patient bedside monitor not calibrated.	Disconnect the pressure cable, and repeat the patient bedside monitor calibration sequence as described in <i>Section 9.7. Connecting and Calibrating the Patient Bedside Monitor (p. 16)</i> .
	Pressure cable not suitable.	Make sure that the pressure cable corresponds to the patient bedside monitor.

SYMPTOMS	POSSIBLE CAUSES	SUGGESTED ACTIONS
Monitor and patient bedside monitor temperature readings do not match.	Patient bedside monitor incorrectly configured.	Configure the patient bedside monitor temperature input to a YSI400 series thermistor.
	Temperature cable not suitable.	Make sure that the temperature cable corresponds to the patient bedside monitor.
	Monitor and patient bedside monitor temperature units are different.	Set the temperature measurement unit in °C or °F on both devices.
No metering of the implantation duration after 1 day or metering blocked.	Failure of the real time clock.	Return the equipment to Sophysa.
No trace or pressure value on the patient bedside monitor, but these values are displayed on the Monitor.	Pressure cable not properly pushed in.	Check pressure cable connections between the patient bedside monitor and the Monitor.
	Pressure cable defective.	Change the pressure cable.
	Patient bedside monitor operating error.	Check the correct operation of the patient bedside monitor.
No temperature value on the patient bedside monitor, but the average	Temperature cable not properly pushed in.	Check temperature cable connections between the patient bedside monitor and the Monitor.

SYMPTOMS	POSSIBLE CAUSES	SUGGESTED ACTIONS
temperature is displayed on the Monitor.	Temperature cable defective.	Change the temperature cable.
	Patient bedside monitor operating error.	Check the correct operation of the patient bedside monitor.
The Monitor is automatically in standby mode.	The Monitor has remained in standby mode (message " CONNECT CATHETER ") for more than 5 minutes.	Make sure the Catheter is properly connected.
Message " CATHETER ZERO FAILURE-CHANGE CATHETER ".	Failure of the Catheter zeroing procedure.	Disconnect and reconnect the Catheter, and restart the Catheter zeroing sequence as described in <i>Section 9.3. Zeroing the Catheter (p. 14)</i> .
	Defective Catheter.	Change the Catheter.
The patient monitor displays the value " 360 " or the message " Abnormal "/" Over range " and the Monitor displays a pressure value.	The patient monitor calibration procedure has not finished so the Monitor sends the abnormal value " 360 mmHg " as an information message to the patient bedside monitor.	Repeat the calibration procedure from the start and ensure the values 0, 30 and 60 mmHg are sent successively in accordance with the procedure described in <i>Section 9.7. Connecting and Calibrating the Patient Bedside Monitor (p. 16)</i> .
The pressure error code "----" is displayed on the Monitor and a message " Abnormal "/" Over Range " or the value " 360 mmHg " is displayed on the patient bedside monitor.	Abnormal pressure: pressure display limits exceeded.	Check the Catheter implantation. Investigate the cause of the abnormal pressure.
	Defective catheter extension cable.	Change the catheter extension cable.
	Defective Catheter.	Change the Catheter if the error message persists.
Temperature error code "--.-" or "---.-" is displayed on the Monitor and a message " Abnormal "/" Over range "/"-?- " is displayed on the patient bedside monitor.	Temperature abnormal: temperature display limits exceeded.	Check the Catheter implantation. Investigate the cause of the abnormal temperature.
	Defective catheter extension cable.	Change the catheter extension cable.
	Defective Catheter.	Change the Catheter if the error message persists.
Abnormal pressure value in relation to the condition of the	Incorrect implantation of the Catheter.	Check the Catheter implantation. Investigate the cause of the abnormal pressure.
	Defective catheter extension cable.	Change the catheter extension cable.

SYMPTOMS	POSSIBLE CAUSES	SUGGESTED ACTIONS
patient observed by the practitioner.	Defective Catheter.	Change the Catheter if the error message persists.
Abnormal temperature value in relation to the condition of the patient observed by the practitioner.	Incorrect implantation of the Catheter.	Check the Catheter implantation. Investigate the cause of the abnormal temperature.
	Defective catheter extension cable.	Change the catheter extension cable.
	Defective Catheter.	Change the Catheter if the anomaly persists.
The flashing message " CONNECT CATHETER " persists after connecting the Monitor with the catheter extension cable and the Catheter.	The catheter extension cable connector is not completely pushed into the socket on the Monitor.	Ensure the catheter extension cable is correctly connected to the Monitor.
	The Catheter is not correctly connected to the catheter extension cable.	Check the catheter extension cable is correctly connected to the Catheter.
	Catheter extension cable damaged.	Replace the catheter extension cable.
	Catheter damaged.	Replace the Catheter.
Loss of monitoring with connected catheter, or Monitor malfunction	Electrostatic discharges	Power the Monitor off and on. If the Power button does not answer, unplug the power cable, remove the battery cover and disconnect the battery for a few seconds. Reconnect the battery, put the battery cover back, plug the power cable back and power on the Monitor. If the Monitor still freezes on the Home page, return the Monitor to after-sales service.
		If error codes "E001", "E002" or "E005" appear: Disconnect and reconnect the catheter. If needed, restart the Monitor. If needed, change the catheter.

18. Technical Specifications

18.1. GENERAL POINTS

The catheter extension cable and the Catheters are the applied parts of the Monitor.

Monitor general specifications	
Item	Specification
Type of monitor	ICP Monitor

Monitor general specifications		
Item	Specification	
Mode of operation	Continuous operation	
Dimensions	L198 mm x H127 mm x D106 mm	
Weight	1.8 kg (4 lbs)	
Power supply	Voltage	100-240 V~
	Consumption	12-80 VA
	Frequency	50-60 Hz
Power cable	Length	- Europe, Switzerland, Brazil, China, South Africa, Australia: 2.50 m - Japan: 2.30 m - USA: 3 m
		Type
Internal battery	Voltage	3.65 V
	Capacity	8.0 Ah
	Energy	29.2 Wh
	Weight	210 g (0.5 lbs)
	Safety	IEC 62133:2017; UL 1642; UN/DOT 38.3
	Dimension	L92 mm x H70 mm x D19 mm
Case	Material	BASF Ultradur® FFree B 4450 G5 LS 25% Glass Filled PBT
Cooling	By convection	
Measurement method	Pressure sensor	Strain gauge piezoresistive sensor. Differential sensor (atmospheric reference)
	Temperature sensor	YSI400 Thermistor
Display	5.7" VGA colour LCD TFT	
	Resolution	640 x 480 pixels
	Viewing angle	80° min
Touch screen	Type	Capacitive
	Material	Glass

Accessories and compatible catheters length		
Item	Length	
Accessories		
Catheter Extension Cable (PSO-EC30)	2 m	
Pressure cable (PSO-MCxx)	2.90 m	
Temperature cable (PSO-MCT-y)	2.90 m	
Mini-USB cable	1.80 m	
Compatible Catheters		
PSO-PB/PSO-PBT PSO-PT/PSO-PTT PSO-VT/PSO-VTT	1 m	

Operation on batteries	
Item	Specification
Battery life	>6 h during valid maintenance period
Indicative charging time for a new battery	10 h for full charge

Environmental specifications		
Item	Specification	
Temperature	Operation	+10 °C (50 °F) to +40 °C (104 °F)
	Storage, transport	-20 °C (-4 °F) to +60 °C (140 °F)
Humidity	Operation	15% to 95% relative humidity without condensation
	Storage, transport	5% to 95% relative humidity
Altitude	Operation	-500 to 3000 m
	Storage, transport	-500 to 4600 m

Measuring and display specifications		
Item	Specification	
ICP	Display range	-40 mmHg to +150 mmHg
	Unit	mmHg
	Resolution	+1 mmHg
	Accuracy	+/-2% of the reading from 0 to +100 mmHg or +/-2 mmHg
	Sampling	100 samples/s
	Smoothing rate	8 s
Systolic and diastolic pressures	Refreshing	1 s
	Systolic range	-40 mmHg to +200 mmHg
Systolic and diastolic pressures	Diastolic range	-50 mmHg to +150 mmHg
	Resolution	1 mmHg (Sys. and Dias.)
ICT	Unit	Celsius (°C) or Fahrenheit (°F) °F = °C x (9/5) + 32 °C = (°F - 32) x (5/9) Equivalence in Kelvin (K): K = °C + 273.15 K = °F x (5/9) + 255.37
	Display range	+20.0 °C to +45.0 °C (+68.0 °F to +113.0 °F)
	Resolution	0.1 °C (0.1 °F)
	Accuracy	Assigned output range +/- 0.2 °C from 25.0 °C to 45.0 °C Assigned extended output range +/- 0.4 °C from 20.0 °C to 25 °C
	Refreshing	1 s
	Mode	Direct

Measuring and display specifications		
Item	Specification	
	Time constant	Less than 10 s for parenchymal Catheters: PSO-PB, PSO-PBT, PSO-PT or PSO-PTT Less than 20 s for ventricular Catheters: PSO-VT or PSO-VTT

Externalization specifications to a patient monitor		
Item	Specification	
ICP output to a patient bedside monitor	Output range (mmHg)	-40 mmHg to +150 mmHg
	Excitation voltages	+2 to +8 Vdc or +2 to +8 Vac
	Max. input voltage	+8 Vdc or +8 Vac
	Output range (Hz)	DC to 5000 Hz
	Sensitivity	+5 μ V/V/mmHg
	Resolution	+0.125 mmHg
	Accuracy	+/- 2% of the reading of 0 to +100 mmHg or +/-2 mmHg
	Sampling	100 samples/s
	Calibration points	0, +30, and +60 mmHg
	Alert pressure	+360 mmHg
Refreshing	10 ms	
ICT output to a patient bedside monitor	Output range	+20.0 °C to +45.0 °C (+68.0 °F to +113.0 °F)
	Sensitivity	Standard YSI 400
	Resolution	0.1 °C (0.1 °F)
	Accuracy	Assigned output range +/- 0.2 °C from 25.0 °C to 45.0 °C Assigned extended output range +/- 0.4 °C from 20.0 °C to 25.0 °C
	Max. input voltage	+5 Vdc
	Refreshing	1 s

Externalization specifications to a PC		
Item	Specification	
Media Format	USB	USB 2.0
	RS232	115200 bauds, 1 start bit, 1 stop bit, no parity bit
	Socket	Mini USB type B female
	Max. input voltage	+5 Vdc
ICP output to a PC	Output range	-40 mmHg to +150 mmHg
	Resolution	+0.1 mmHg
	Sampling	100 samples/s
	Alert pressure	+360 mmHg
	Refreshing	10 ms
ICT output to a PC	Output range	+20.0 °C to +45.0 °C +68.0 °F to +113.0 °F
	Unit	Celsius/Fahrenheit
	Resolution	0.01 °C/0.01 °F

Externalization specifications to a PC		
Item	Specification	
	Refreshing	1 s

Internal history specifications		
Item	Specification	
History format	Mode1	24 h of data in real time + 14 days of average data
	Mode2	15 days of data in real time
	Real time data	Interval of 10 ms
	Average data	Interval of 1 s (Storage of the displayed value)
Data saved	ICP, ICT, events	
Event	Max number of characters	50 characters per event
	Max number of events	200 events per history life

History of exports and imports specifications		
Item	Specification	
Media Format	USB stick	FAT32 format
	Max. output voltage	+5 Vdc
Exportable internal history format	PDF file	
	History of averages	Interval of 20 s for the ICP and ICT. Encrypted file
	History of real time data	Interval of 10 ms. Encrypted file
Exported data	ICP, ICT, events	
Importable history format	History of averages	
	History of real time data	

Specifications for pole clamp fixation		
Item	Specification	
Orientability	4 positions, engaging at 90-degree intervals	
Fixation Support	Vertical pole	Example: IV pole
	Horizontal rail	Example: bed rail
Fixation diameter	Vertical pole: diameter of 10 mm to 60 mm	
	Horizontal rail: diameter of 20 mm to 60 mm	
Material	Aluminum	

Safety specifications		
Item	Specification	
Class	I	
Input	Type BF	ICP/ICT
Protection index	IP41	4: Protected against solid bodies of more than 1 mm 1: Protected against dripping water equivalent to 1 mm rainfall per minute.

Safety specifications	
Item	Specification
Operation mode	Continuous
Importable history format	History of averages History of real time data
Protection against short-circuits	High cut-off capacity fuse: LITTELFUSE 021502.5MXESPP (215SP T2.5A/250V, single cap pigtail, axial leaded, 5 x 20 mm)

The Monitor complies with the following standards:

- IEC60601-1:2005/A1:2012/AC1:2014/A2:2020
- IEC60601-1-8:2006/A1:2012/A11:2017/A2:2020
- IEC60601-1-6:2010/A1:2013
- IEC 80601-2-49:2018
- NF EN ISO 80601-2-56:2017/A1:2020
- IEC60601-1-2:2014/A1:2020
- IEC62304:2006
- UL 60601-1:2006
- IATA DGR – International Air Transport Association Dangerous Goods Regulation

Restarting monitoring following a power cut or powering off					
	Battery status	ICP and ICT monitoring	Restarting ICP and ICT monitoring	Restarting ICP monitoring on patient monitor	Restarting ICT monitoring on patient monitor
Power cut	OK	Conserved	Conserved	Conserved	Conserved
Power cut	Flat	Stopped	Yes	No. Recalibration necessary	Yes
Monitor powered off	OK or flat	Stopped	Yes	No. Recalibration necessary	Yes

18.2. SPECIFICATIONS CONCERNING ALARMS

The Monitor generates two types of visual/audible alarms:

- Physiological alarms which alert the personnel that the average ICP or/and the average ICT has exceeded the alarm thresholds.
- Technical alarms which warn the personnel there is a problem with the Monitor itself or the Catheter.

18.2.1. Physiological alarms

Physiological parameter	Clinical Priority	Response time	Sound indicators	Visual indicators
ICP	High	Prompt	Three-pulse sound, pause for 300 ms, two-pulse sound, pause for 500 ms, three-pulse sound, pause for 300 ms, two-pulse sound The pulses are separated by 100 ms Sequence repetition interval: 2.5 s The pulse volume is 59 dBa (ref 20µPa)	The ICP display area flashes red at a frequency of 2 Hz. The ICP curve cursor turns red. An arrow indicates the direction in which the threshold is exceeded on the ICP alarm scale. The word ALARM displays in the ICP display area.
ICT	Medium	Delayed	Three-pulse sound The pulses are separated by 100 ms Sequence repetition interval: 7.5 s The pulse volume is 59 dBa (ref 20µPa)	The ICT display area flashes yellow at a frequency of 0.5 Hz. An arrow indicates the direction in which the threshold is exceeded on the ICT alarm scale. The word ALARM displays in the ICT display area.

18.2.2. Technical alarms

Technical parameter	Alarm condition	Priority	Response time	Sound indicators	Visual indicators
Pressure sensor status	Fault in the Catheter pressure sensor	High	Prompt	Three-pulse sound, pause for 300 ms, two-pulse sound, pause for 500 ms, three-pulse sound, pause for 300 ms, two-pulse sound The pulses are separated by 100 ms Sequence repetition interval: 2.5 s The pulse volume is 59 dBa (ref 20µPa)	The message E001 ALARM displays. The display area flashes red at a frequency of 2 Hz.

Technical parameter	Alarm condition	Priority	Response time	Sound indicators	Visual indicators
Temperature sensor status	Fault in the Catheter temperature sensor	High	Prompt	Three-pulse sound, pause for 300 ms, two-pulse sound, pause for 500 ms, three-pulse sound, pause for 300 ms, two-pulse sound The pulses are separated by 100 ms Sequence repetition interval: 2.5 s The pulse volume is 59 dBA (ref 20µPa)	The message E005 ALARM displays. The display area flashes red at a frequency of 2 Hz.
Calibration status	Catheter calibration fault	High	Prompt	Three-pulse sound, pause for 300 ms, two-pulse sound, pause for 500 ms, three-pulse sound, pause for 300 ms, two-pulse sound The pulses are separated by 100 ms Sequence repetition interval: 2.5 s The pulse volume is 59 dBA (ref 20µPa)	The message E002 ALARM displays. The display area flashes red at a frequency of 2 Hz.
ICP measurement range	Average ICP outside measurement range	High	Prompt	Three-pulse sound, pause for 300 ms, two-pulse sound, pause for 500 ms, three-pulse sound, pause for 300 ms, two-pulse sound The pulses are separated by 100 ms Sequence repetition interval: 2.5 s The pulse volume is 59 dBA (ref 20µPa)	The message E001 ALARM displays. The display area flashes red at a frequency of 2 Hz.

Technical parameter	Alarm condition	Priority	Response time	Sound indicators	Visual indicators
ICT measurement range	Average ICT outside measurement range	High	Prompt	Three-pulse sound, pause for 300 ms, two-pulse sound, pause for 500 ms, three-pulse sound, pause for 300 ms, two-pulse sound The pulses are separated by 100 ms Sequence repetition interval: 2.5 s The pulse volume is 59 dBA (ref 20µPa)	The message E005 ALARM displays. The display area flashes red at a frequency of 2 Hz.

NOTE

The DEACTIVATED ALARM status does not disable the signals (visual and audible) of the technical alarms.

Disconnection of the Catheter disables the signals (visual and audible) of the technical alarms.

Operator position in terms of alarm readability: in front of the Pressio® 2 ICP Monitor screen.

Alarm condition delay							
Physiological parameter	ICP	ICT	Fault in the Catheter pressure sensor	Fault in the Catheter temperature sensor	Catheter calibration fault	Average ICP outside measurement range	Average ICT outside measurement range
Average alarm condition delay	8 s	1 s	<1 s	<1 s	<1 min	<1 s	<1 s
Statistical condition statistical delay	8 s	1 s	<1 s	<1 s	<1 min	<1 s	<1 s
Average alarm generation delay	0 s	0 s	<1 s	<1 s	<1 min	<1 s	<1 s
Statistical alarm generation delay	0 s	0 s	<1 s	<1 s	<1 min	<1 s	<1 s

Alarm condition delay							
Physiological parameter	ICP	ICT	Fault in the Catheter pressure sensor	Fault in the Catheter temperature sensor	Catheter calibration fault	Average ICP outside measurement range	Average ICT outside measurement range
Sum of the ALARM SIGNAL GENERATION DELAY and average of ALARM CONDITION DELAY	8 s	1 s	<1 s	<1 s	<1 min	<1 s	<1 s
Sum of the ALARM SIGNAL GENERATION DELAY and distribution statistics of the ALARM CONDITION DELAY	8 s	1 s	<1 s	<1 s	<1 min	<1 s	<1 s

Behavior of alarms following a power cut or powering off			
	Battery status	Alarm status	Alarm thresholds
Power cut ≤ 30 s	OK	Conserved	Conserved
Power cut > 30 s	OK	Conserved	Conserved
Power cut > 30 s	Flat	Activated (by default)	Conserved
Monitor powered off	OK or flat	Activated (by default)	Conserved

19. Electromagnetic Compatibility

WARNING

Use of the Monitor adjacent to or stacked with other equipment should be avoided because it could result in improper operation. If such use is necessary, the Monitor and the other equipment should be observed to verify that they are operating normally.

WARNING

Use of accessories, transducers and cables other than those specified or provided by Sophysa could result in increased electromagnetic emissions or decreased electromagnetic immunity of this equipment and result in improper operation.

NOTE

The emission characteristics of the Monitor make it suitable for use in industrial areas and hospitals (CISPR 11 class A).

If it is used in a residential environment (for which CISPR 11 class B is normally required), the Monitor might not offer adequate protection to radio-frequency communication services. The user might need to take mitigation measures, such as relocating or re-orienting the equipment.

19.1. CONSEQUENCES OF ELECTROSTATIC OR ELECTROMAGNETIC DISCHARGES

19.1.1. On the Monitor, the cables or the sensor

In case of electrostatic discharge or electromagnetic disturbance, find below the behavior that the Monitor, the cables or the sensor might have:

- If a strong electrostatic discharge occurs on the Monitor, the cables or the sensor:
 - the mean ICP or ICT value can be temporarily affected,
 - the ICP curve can show temporary peaks of high amplitude.
- If an electrostatic discharge occurs near the Monitor, temporary error “E001”, “E002” or “E005” may display on the Monitor.
- If an electromagnetic disturbance occurs on the Monitor, the cables or the sensor:
 - the mean ICP or ICT value can be affected,
 - the ICP curve can show abnormal ripples.

19.1.2. On the USB ports

The USB ports (USB 2.0 port and Mini-USB port) might also be impacted by electrostatic discharges.

NOTICE

The USB 2.0 port can be damaged by important electrostatic discharges. In this case, return the Monitor to the after-sales service.

NOTICE

If a strong electrostatic discharge occurs on one of the USB ports, the internal power supply may be damaged. Return the Monitor to the after-sales service.

NOTE

If a strong electrostatic discharge occurs on one of the USB ports, the Moniteur may restart automatically.

19.1.3. On the Monitor outlets and inlet

NOTICE

In an electrostatic discharge occurs on the ICP or ICT outlets, or on the catheter extension cable inlet, their functions may be damaged or may cease to function. Return the Monitor to the after-sales service.

19.2. GUIDANCE AND MANUFACTURER'S DECLARATION TABLES

Guidance and manufacturer's declaration – Electromagnetic emissions		
The Monitor is intended to be used in the electromagnetic environment specified below. The customer or user of the Monitor should assure that it is used in such an environment. Deviations from emission and immunity environment for this device may affect its expected service life.		
Emission test	Compliance	Electromagnetic environment – Guidance
RF emissions CISPR 11	Group 1	The Monitor uses RF energy only for its internal functions. Consequently, its RF emissions are very low and are not likely to cause any interference with nearby electronic equipment.
RF emissions CISPR 11	Class A	The Monitor is suitable for use in all establishments, including domestic establishments and those directly connected to the public supply network for low voltage electricity supplying buildings for domestic use.
Harmonic distortion IEC 61000-3-2	Class A	
Voltage fluctuations and flicker IEC 61000-3-3	Compliant	

Guidance and manufacturer's declaration – Electromagnetic immunity	
The Monitor is intended to be used in the electromagnetic environment specified below. The customer or user of the Monitor should assure that it is used in such an environment. Deviations from emission and immunity environment for this device may affect its expected service life.	

Guidance and manufacturer's declaration – Electromagnetic immunity			
Immunity test	Test level IEC60601-1-2	Compliance level	Electromagnetic environment – Guidance
Electrostatic Discharge (ESD) IEC 61000-4-2	±8 kV on contact ± 2 kV, ± 4 kV, ± 8 kV, ± 15 kV in air	±8 kV on contact ± 2 kV, ± 4 kV, ± 8 kV, ± 15 kV in air	Floors should be of wood, concrete or ceramic tiles. If floors are covered with synthetic material, relative humidity should be at least 30%. Transient phenomena may occur on the ICP curve.
Radiated RF EM Fields IEC 61000-4-3	3 V/m 80 MHz – 2.7 GHz 80 % AM at 1 kHz	3 V/m 80 MHz – 2.7 GHz 80 % AM at 1 kHz	<p>WARNING</p> <p>Portable RF communications equipment (including peripherals such as antenna cables and external antennas) should be used no closer than 30 cm (12 inches) to any part of the Monitor, including cables specified by the manufacturer. Otherwise, degradation of the performance of this equipment could result.</p> <p>Interference may occur in the vicinity of equipment containing a RF transmitter.</p>
Proximity fields from RF wireless communications equipment IEC 61000-4-3	Band/Test level 380 - 390 MHz / 27 V/m 430 - 470 MHz / 28 V/m 704 - 787 MHz / 9 V/m 800 - 960 MHz / 28 V/m 1,700 - 1,990 MHz / 28 V/m 2,400 - 2,570 MHz / 28 V/m 5,100 - 5,800 MHz / 9 V/m	Band/Test level 380 - 390 MHz / 27 V/m 430 - 470 MHz / 28 V/m 704 - 787 MHz / 9 V/m 800 - 960 MHz / 28 V/m 1,700 - 1,990 MHz / 28 V/m 2,400 - 2,570 MHz / 28 V/m 5,100 - 5,800 MHz / 9 V/m	
RATED power frequency magnetic fields IEC 61000-4-8	30 A/m 50 Hz or 60 Hz	30 A/m 50 Hz or 60 Hz	Power frequency magnetic fields should be at levels characteristic of a typical location in a typical commercial or hospital environment.
Electrical fast transients / bursts IEC 61000-4-4	±2 kV 100 kHz repetition frequency	±2 kV 100 kHz repetition frequency	The quality of the electricity supply network should be that of a typical commercial or hospital environment.

Guidance and manufacturer's declaration – Electromagnetic immunity			
Surges line-to-line IEC 61000-4-5	±0.5 kV, ±1 kV	±0.5 kV, ±1 kV	The quality of the electricity supply network should be that of a typical commercial or hospital environment.
Surges line-to-ground IEC 61000-4-5	±0.5 kV, ±1 kV, ±2 kV	±0.5 kV, ±1 kV, ±2 kV	The quality of the electricity supply network should be that of a typical commercial or hospital environment.
Conducted disturbances induced by RF fields IEC 61000-4-6	3 V 0.15 MHz – 80 MHz 6 V in ISM bands between 0.15 MHz and 80 MHz 80 % MA at 1 kHz	3 V 0.15 MHz – 80 MHz 6 V in ISM bands between 0.15 MHz and 80 MHz 80 % MA at 1 kHz	It is possible that ripples may appear on the ICP curve. Keep the source of disturbance away from the cables of the Monitor.
Voltage dips	0 % U_T ; 0.5 cycle At 0°, 45°, 90°, 135°, 180°, 225°, 270° and 315°	0 % U_T ; 0.5 cycle At 0°, 45°, 90°, 135°, 180°, 225°, 270° and 315°	The quality of the electricity supply

Guidance and manufacturer's declaration – Electromagnetic immunity			
IEC 61000-4-11	0 % U_T ; 1 cycle and 70 % U_T ; 25/30 cycles Single phase: at 0°	0 % U_T ; 1 cycle and 70 % U_T ; 25/30 cycles Single phase: at 0°	network should be that of a typical commercial or hospital environment. If the user of the Monitor requires continuous operation during power cuts, it is recommended that the Monitor is supplied by an energy source not subject to cuts, or supplied by a battery.
Voltage interruptions IEC 61000-4-11	0 % U_T ; 250/300 cycles	0 % U_T ; 250/300 cycles	
Proximity magnetic fields IEC 61000-4-39	134.2 kHz Pulse modulation 2.1 kHz, 65 A/m	134.2 kHz Pulse modulation 2.1 kHz, 65 A/m	-
	13.56 MHz Pulse modulation 50 kHz, 7.5 A/m	13.56 MHz Pulse modulation 50 kHz, 7.5 A/m	-
<p>NOTE U_T is the AC mains voltage prior to application of the test level.</p>			

20. References

Table 1. Pressio® Catheter Kits

PSO-PB	Pressio® ICP monitoring kit, parenchymal with bolt
PSO-PBT	Pressio® ICP and ICT monitoring kit, parenchymal with bolt
PSO-PT	Pressio® ICP monitoring kit, parenchymal tunneling
PSO-PTT	Pressio® ICP and ICT monitoring kit, parenchymal tunneling
PSO-VT	Pressio® ICP monitoring kit, ventricular tunneling with external CSF drainage function
PSO-VTT	Pressio® ICP and ICT monitoring kit, ventricular tunneling with external CSF drainage function

Table 2. Pressio® Monitoring System

PSO-4000	Pressio® 2 ICP Monitor Power cable and catheter extension cable (PSO-EC30) included
----------	--

Table 3. Pressio® Accessories

PSO-EC30	Catheter extension cable (included with PSO-4000, also available separately)
PSO-MCxx	Pressure cable – MC01: PHILIPS (AGILENT) - 12 pins – MC02: SIEMENS (SIRECUST) - 10 pins – MC03: SPACELABS & MINDRAY - 6 pins – MC04: GE DATEX-Ohmeda - 10 pins – MC05: GE Solar (MARQUETTE) - 11 pins – MC08: NIHON KOHDEN - 5 pins
PSO-MCT-y	Temperature cable – MCT-A: PHILIPS (AGILENT) - 2 pins – MCT-B: SIEMENS - 7 pins – MCT-C: SPACELABS - 10 pins – MCT-E: GE Solar (MARQUETTE), GE DATEX-Ohmeda - 11 pins – MCT-F: HELLIGE, DATEX-Ohmeda, NIHON KOHDEN, MINDRAY & DATASCOPE - JACK 6.35 mm
PSO-DR	Single use, disposable drill
PSO-MRI	Pressio® MRI Support For positioning Pressio® Catheter during MRI examination

Table 4. Year of first CE marking

PSO-4000	2016
PSO-EC30	2016
PSO-MCxx	2005
PSO-MCT-y	2010

***Technical specifications and list of product references
may be modified without notice.***

Availability may vary according to country.

This page is intentionally left blank.



■ Sophysa

5, rue Guy Moquet
91400 Orsay
France
Tel.: +33 (0)1 69 35 35 00
Fax: +33 (0)1 69 35 36 90
contact@sophysa.com

Sophysa Benelux

Axis Parc
Rue Emile Francqui, 4
B-1435 Mont-Saint-Guibert
Belgium
Tel.: +32 (0)10 81 45 30
Fax: +32 (0) 10 81 43 04
infobenelux@sophysa.com

Sophysa USA

503 E Summit Street, Suite 5
Crown Point IN 46307
USA
Tel.: +1 219 663 7711
Fax: +1 219 663 7741
contact@sophysa.us

www.sophysa.com

Pressio® is a registered trademark of Sophysa.

©2023 Sophysa. All rights reserved.